

<b>1</b>	<b>Pin Connection</b>	G-138
<b>2</b>	<b>Function</b>	G-138
2.1	Input voltage .....	G-138
2.2	Overcurrent protection .....	G-138
2.3	Isolation .....	G-138
<b>3</b>	<b>Wiring to Input/Output Pin</b>	G-138
<b>4</b>	<b>Series Operation and Parallel Operation</b>	G-139
4.1	Series operation .....	G-139
4.2	Parallel redundancy operation .....	G-140
<b>5</b>	<b>Assembling and Installation Method</b>	G-140
5.1	Installation method .....	G-140
5.2	Derating .....	G-140
<b>6</b>	<b>Input Voltage/Current Range</b>	G-141
<b>7</b>	<b>Cleaning</b>	G-141
<b>8</b>	<b>Soldering</b>	G-141
<b>9</b>	<b>Input/Output Pin</b>	G-141
<b>10</b>	<b>Peak Current (Pulse Load)</b>	G-142

# 1 Pin Connection

No.	Pin connection	Function
①	+DC(+V) INPUT	+Side of input voltage
②	-DC(-V) INPUT	-Side of input voltage
③	+DC(+V) OUTPUT	+Side of output voltage
④	COMMON	GND of output voltage (Only applicable for Dual output)
⑤	-DC(-V) OUTPUT	-Side of output voltage
⑥	Case connecting pin	If connected to -side of input, the case potential can be fixed and the value of radiation noise can be reduced.

## ●Single output

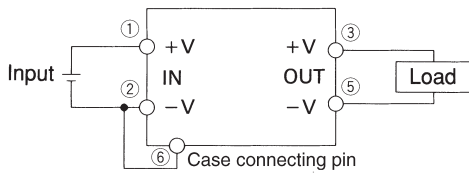

Fig.1.1 Single output of pin connection

## ●Dual (±) output

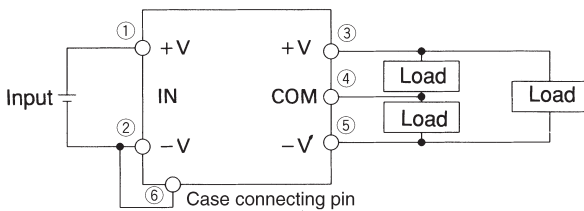

Fig.1.2 Dual output of pin connection

## ●Case connecting pin

Case connecting pin is available. By connecting this pin to -side of input, the radiation noise from main body can be reduced.

# 2 Function

## 2.1 Input voltage

■If the wrong input is applied, the unit will not operate properly and/or may be damaged.

## 2.2 Overcurrent protection

■Overcurrent protection circuit is built-in to and comes into effect over of the rated current.

Overcurrent protection prevents the unit from short circuit and over current condition of less than 20 sec. The unit automatically recovers when the fault condition is cleared.

■The power supply which has a current foldback characteristics may not start up when connected to nonlinear load such as lamp, motor or constant current load.

See the characteristics below.

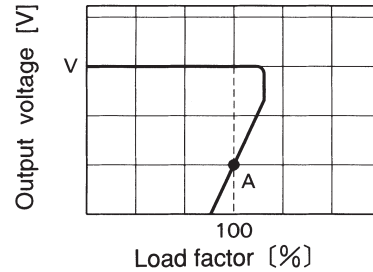

——: Load characteristics of power supply.

-----: Characteristics of load (lamp, motor, constant current load, etc.).

Note: In case of nonlinear load, the output is locked out at A point.

Fig.2.1 Current foldback characteristics

## 2.3 Isolation

■For a receiving inspection, such as Hi-Pot test, gradually increase (decrease) the voltage for the start (shut down). Avoid using Hi-Pot tester with the timer because it may generate voltage a few times higher than the applied voltage, at ON/OFF of a timer.

# 3 Wiring to Input/Output Pin

■Input filter is built-in. A capacitor Ci, if installed near the input terminal, will lower the input conducted noise from converter due to the formation of the π type filter.

■When the distance from the DC line to the unit is greatly extended, it makes the input feedback noise much higher and the input voltage several times higher than the normal level when turned ON. If this happens, the output power also becomes unstable. In order to prevent the unit from failing in this way; please connect Ci to the input terminal. In addition, when the filter with "L" is used, please connect Ci to the input terminal.

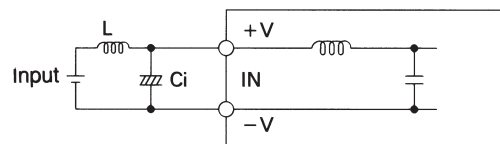

Fig.3.1 Connecting method of external capacitor at input terminal

Table 3.1 Capacity of external capacitor at input terminal: Ci[μF]

Model	ZS1R5	ZS3	ZS6	ZS10
Input voltage(V)	ZW1R5	ZW3	ZW6	ZW10
5	100	220	470	470
12	47	100	220	220
24	33	47	100	100
48	10	22	47	47

■To lower the ripple voltage further, install an external capacitor Co at output terminal as shown below.

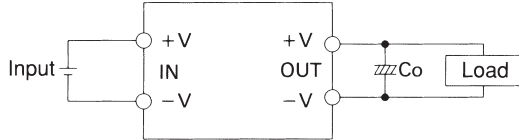

Fig.3.2 Connecting method of external capacitor at input terminal

Table 3.2 Capacity of external capacitor at output terminal: Co[μF]

Model	ZS1R5	ZS3	ZS6	ZS10
Output voltage (V)	ZW1R5	ZW3	ZW6	ZW10
5	100	220	220	220
12	100	100	100	100
15	100	100	100	100

■When the distance between load and DC output is long, please install capacitor at load as below.

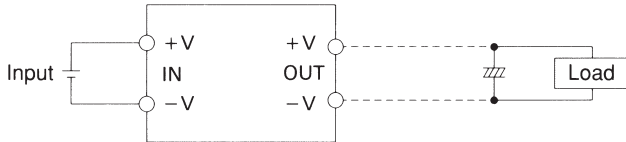

Fig.3.3 Connection method of capacitor at load

■Due to the high operating frequency, this converter generates a little common mode noise. In order to lower the noise further; install capacitor between -V input and -V output as shown below (Fig.3.4 Circuit to lower common mode noise).

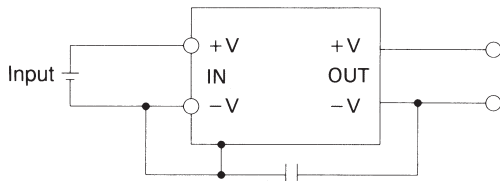

Fig.3.4 Circuit to reduce common mode noise

Reverse input voltage protection

■Avoid the reverse polarity input voltage. It will damage the power supply.

It is possible to protect the unit from the reverse input voltage by installing an external diode as shown in Fig.3.5.

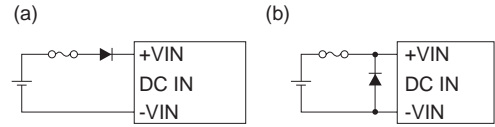

Fig.3.5 Reverse input voltage protection

## 4 Series Operation and Parallel Operation

### 4.1 Series operation

●ZS1R5/ZW1R5 · ZS3/ZW3 · ZS6/ZW6

■Series operation is available by connecting the outputs of two or more power supplies as shown below.

Output currents in series connection should be lower than the lowest rated current in each unit.

But at series operation with same output voltage, diode is not required to attach even if at (a).

(a) When the output voltage is less than 5V.

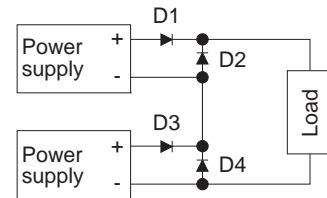

D1~D4: Please use Schottky Barrier Diode.

(b) When the output voltage is more than 12V.

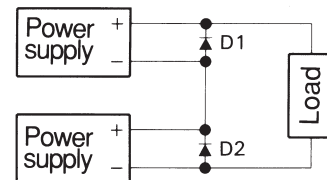

D1 · D2: Please use Schottky Barrier Diode.

●ZS10/ZW10

■Series operation is available. However, output current in series connection should be lower than the lowest rated current in each unit.

### 4.2 Parallel redundancy operation

Parallel redundancy operation is available by connecting below.

$$I_1, I_2 \leq \text{the rated current value}$$

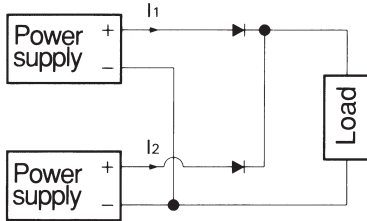

## 5 Assembling and Installation Method

### 5.1 Installation method

The unit can be mounted in any direction. Position them with proper intervals to allow enough air ventilation. Ambient temperature around each power supply should not exceed the temperature range shown in derating curve.

Avoid placing the DC input line pattern lay out underneath the unit because it will increase the line conducted noise. Make sure to leave an ample distance between the line pattern lay out and the unit. Also, avoid placing the DC output line pattern underneath the unit because it may increase the output noise. Lay out the pattern away from the unit.

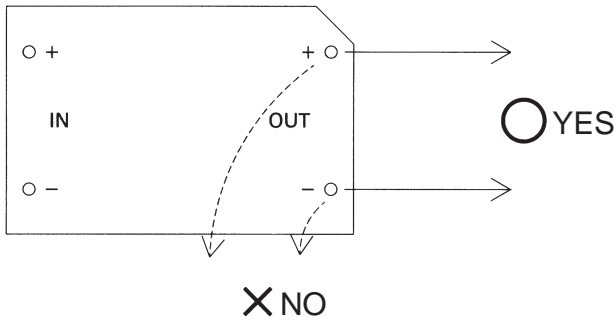

Fig.5.1 Pattern wiring

### 5.2 Derating

By derating the output current, it is possible to operate the unit from -10°C to +60°C for ZS(W)1R5~ZS6 and from -10°C to +70°C for ZS(W)10.

When unit mounted any way other than in drawings below, it is required to consider ventilated environments by forced air cooling or temperature/load derating. For details, please consult our sales or engineering department.

#### ●Except ZS(W)10

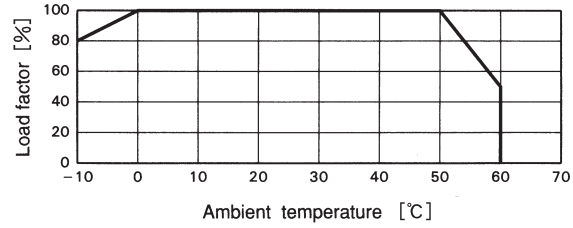

#### ●ZS(W)10

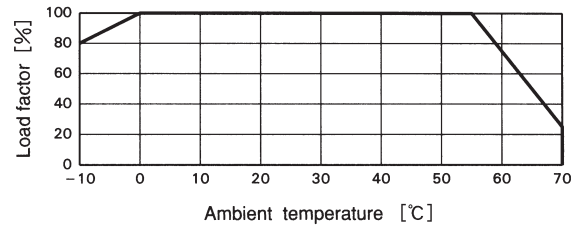

The temperature increase of case surface at full load is shown by below table as referenced data.

Table 5.1 The surface temperature of case increase data (Z series)  
(Unit: deg)

Input voltage	Output voltage	1.5W	3W	6W	10W
5V	5V	20	25	28	37
	12V	21	27	30	43
	15V	22	28	28	40
	±12V	20	27	34	39
	±15V	20	29	32	44
12V	5V	14	18	24	34
	12V	13	22	23	34
	15V	14	21	22	28
	±12V	13	18	21	36
	±15V	12	20	24	34
24V	5V	18	14	25	33
	12V	17	17	21	29
	15V	16	19	22	29
	±12V	17	17	25	32
	±15V	18	19	24	29
48V	5V	15	25	30	32
	12V	12	29	25	27
	15V	12	22	28	26
	±12V	16	21	24	33
	±15V	16	20	25	33

## 6 Input Voltage/Current Range

- When a non-regulated source is used as a front end, make sure that the voltage fluctuation together with the ripple voltage will not exceed the input voltage range.
- Select the converter that is able to handle the start-up current ( $I_p$ ).

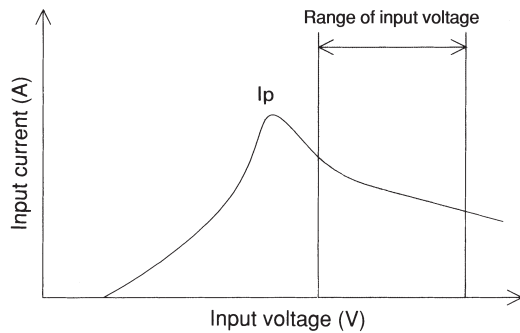

Fig.6.1 Input current characteristics (Except ZS10, ZW10)

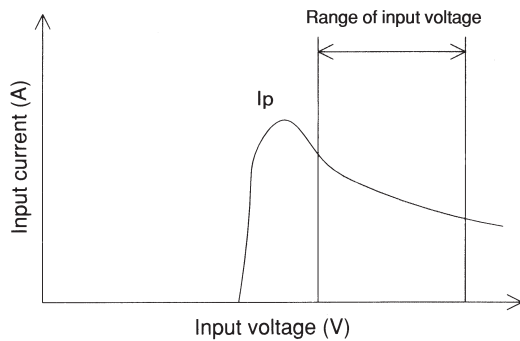

Fig.6.2 Input current characteristics (ZS10, ZW10)

## 7 Cleaning

- Cleaning agents :

No.	Classification	Cleanig agents
1	Water type	Pine Alpha ST-100S(ARAKAWA CHEMICAL CO.)
2		Clean Through 750H(KAO Corporation)
3	Solvent type	IPA
4		Asahiklin AK-225AES(ASAHI GLASS CO.)

- Cleaning period

The total time of varnishing, ultrasonic wave and vapor should be within 2 minutes. In case of ultrasonic wave cleaning, the ultrasonic should be less than 15kw/m<sup>3</sup>. During cleaning to drying (the condition that cleaning liquid is soaked into the ink of name plate), do not touch on the surface of name plate.

- After cleaning, dry them enough.

## 8 Soldering

- Flow soldering : 260°C less than 15 seconds.
- Soldering iron : 450°C less than 5 seconds.

## 9 Input/Output Pin

- When too much stress is applied on the input/output pins of the unit, the internal connection may be weakened. As below Fig. 8.1, avoid applying stress of more than 9.8N (1kgf) on the pins horizontally and more than 19.6N (2kgf) vertically.
- The input/output pins are soldered on PCB internally, therefore, do not pull or bend them with abnormal forces.
- When additional stress is expected to be put on the input/output pins because of vibration or impacts, fix the unit on PCB (using silicone rubber or fixing fittings) to reduce the stress onto the input/output pins.

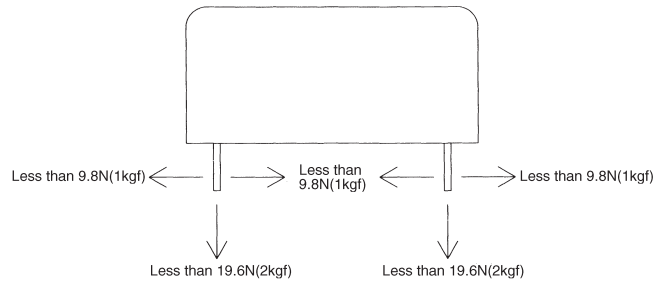
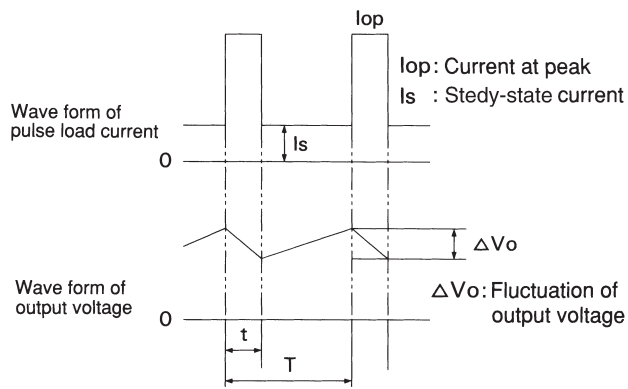
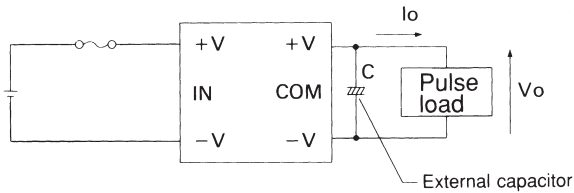

Fig.8.1 Stress onto the pins

## 10 Peak Current (Pulse Load)

■ It is possible to supply the pulse current for the pulse load by connecting the capacitor externally at the output side.



■ The average current  $I_{av}$  of output is shown in below formula.

$$I_{av} = I_s + \frac{(I_{op} - I_s) t}{T}$$

■ The required electrolytic capacitor C is found by below formula.

$$C = \frac{(I_{op} - I_{av}) t}{\Delta V_o}$$