

1 Terminal Block A-144**2** Function A-144

- 2.1 Input voltage range A-144
- 2.2 Inrush current limiting A-144
- 2.3 Overcurrent protection A-144
- 2.4 Overvoltage protection A-145
- 2.5 Output voltage adjustment range A-145
- 2.6 Remote ON/OFF A-145
- 2.7 Isolation A-145
- 2.8 Thermal protection A-145

3 Series Operation and Parallel Operation A-145

- 3.1 Series operation A-145
- 3.2 Parallel operation/master-slave operation A-145

4 Assembling and Installation Method A-146

- 4.1 Installation method A-146
- 4.2 Derating A-146
- 4.3 Mounting screw A-147

5 Peak Loading A-148

1 Terminal Block

AD

●AD240

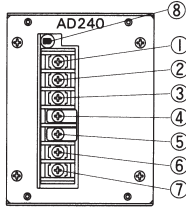

- ①+Output
- ②-Output
- ③Frame ground
- ④ } Input voltage selecting terminal
- ⑤ } Short: AC 85 - 132V Open: AC170 - 264V
- ⑥AC(L)
- ⑦AC(N)
- ⑧Output voltage adjustable potentiometer

●AD480

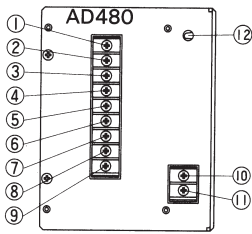

- ① } +Output
- ② } +Output
- ③ } -Output
- ④ } -Output
- ⑤ Remote ON/OFF(RC)
- ⑥ Remote ON/OFF(RCG)
- ⑦ Frame ground
- ⑧ } Input voltage selecting terminal
- ⑨ } Short: AC 85 - 132V Open: AC170 - 264V
- ⑩ AC(N)
- ⑪ AC(L)
- ⑫ Output voltage adjustable potentiometer

●AD960

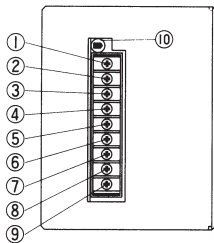

- ① } +Output
- ② } +Output
- ③ } -Output
- ④ } -Output
- ⑤ Voltage balance(VB)
- ⑥ Current balance(CB)
- ⑦ Frame ground
- ⑧ AC(L)
- ⑨ AC(N)
- ⑩ Output voltage adjustable potentiometer

2 Function

2.1 Input voltage range

●AD240 · AD480

- The range is from AC85V to AC132V or AC170V to AC264V (user selectable).
- By changing the input voltage selector between VS1 - VS2 (short or open), either AC100V or AC200V is possible.
 - Short — AC85V to AC132V
 - Open — AC170V to AC264V
- The unit is shipped from the factory for AC200V (open condition). In the case of AC100V, install the short-piece between VS1 and VS2.
- If the wrong connection is made for short/open, the power supply may be damaged. The input voltage should be within the above range.

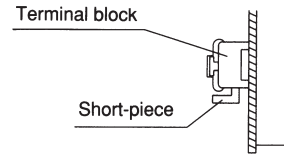

Short-piece should be attached as per above drawing.

●AD960

- The range is from AC170V to AC264V or DC240V to DC370V.
- AC input voltage must have a range from AC170V to AC264V or DC240V to DC370V for normal operation. If the wrong input is applied, the unit will not operate properly and/or may be damaged.

2.2 Inrush current limiting

- Inrush current limiting is built-in.
- If a switch on the input side is installed, it has to be the one handling the input inrush current.
- The thyristor technique is used for protection from inrush current.
- When power is turned ON/OFF repeatedly within a short period of time, it is necessary to have enough time between power ON and OFF to operate resistance circuit for inrush current.

2.3 Overcurrent protection

- The overcurrent protection circuit is built-in to prevent the unit from a short circuit and overcurrent condition. The unit automatically recovers when the fault condition is cleared.

●AD480

■When short/overcurrent condition continues more than 10 seconds, average overcurrent circuit (operated at 110% of rated current) operates, and it reduces the current by hang of voltage. When cause of activation of overcurrent protection is removed, the output will be automatically recovered.

2.4 Overvoltage protection

●AD960

■The overvoltage protection circuit is built-in and comes into effect at 115 - 140% of the rated voltage. The AC input should be shut down if overvoltage protection is in operation. The minimum interval of AC recycling for recovery is 5 minutes.

★ The recovery time varies depending on input voltage.

Remarks:

Please avoid applying the over-rated voltage to the output terminal. Power supply may operate incorrectly or fail. In case of operating a motor etc. , please install an external diode on the output terminal to protect the unit.

2.5 Output voltage adjustment range

- Adjustment of output voltage is possible by using potentiometer.
- Output voltage is increased by turning potentiometer clockwise and is decreased by turning potentiometer counterclockwise.

2.6 Remote ON/OFF

●AD480

■The ground terminal of remote ON/OFF circuit is connected with -V output terminal.

Between RC and RCG: Output voltage is ON at "High" level or open circuit.

Between RC and RCG: Output voltage is OFF at "Low" level or short circuit.

When RC terminal is "Low" level, fan out current is 5mA.

2.7 Isolation

■For a receiving inspection, such as Hi-Pot test, gradually increase (decrease) the voltage for the start (shut down). Avoid using Hi-Pot tester with the timer because it may generate voltage a few times higher than the applied voltage, at ON/OFF of a timer.

●AD480

■If the unit is tested on the isolation between input & output and output & FG, remote ON/OFF must be shorted to output.

2.8 Thermal protection

●AD960

■Thermal protection is built-in. If this function comes into effect, shut down the output, eliminate all possible causes of overheating, and drop the temperature to normal level. Output voltage recovers after applying input voltage. To prevent the unit from overheating, avoid using the unit in a dusty, poorly ventilated environment.

- (1) Over 45°C (Ambient temperature)
- (2) Poor ventilation
- (3) Excessive output current for over 10 seconds

3 Series Operation and Parallel Operation

3.1 Series operation

■Series operation is available by connecting the outputs of two or more power supplies, as shown below. Output current in series connection should be lower than the lowest rated current in each unit.

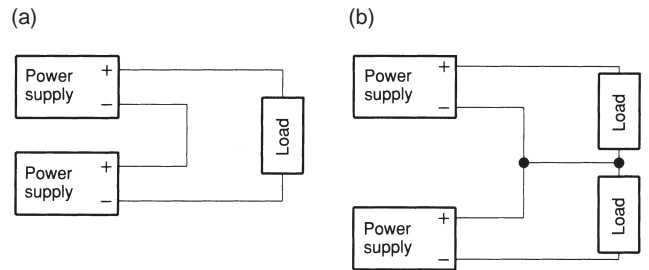

3.2 Parallel operation/master-slave operation

●AD240 · AD480

■Parallel redundancy operation is available by connecting the units as shown below.

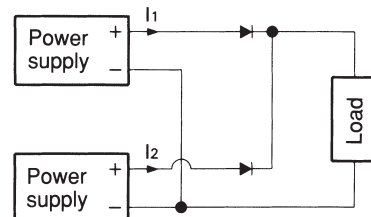

AD

■Values of I₁ and I₂ become unbalanced by a slight difference of the output voltage. Make sure that the output voltage of units is of equal value and the output current from each power supply does not exceed the rated current.

$$I_1, I_2 \leq \text{the rated current value}$$

●AD960

- Parallel operation is available by connecting below.
- As variance of output current drew from each power supply is maximum 10%, the total output current must not exceed the value determined by the following equation.

(Output current in parallel operation)
 = (the rated current per unit) × (number of unit) × 0.9

When the number of units in parallel operation increases, input current increases at the same time. Adequate wiring design for input circuitry is required, such as circuit pattern, wiring and current capacity for equipment.

In parallel operation, the maximum operative number of units is 5.

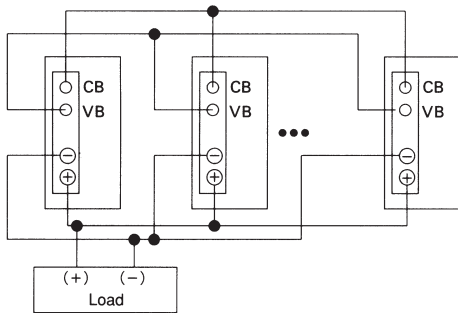

- Output voltage in parallel operation is adjustable by using the potentiometer of the "master" unit. Select one power supply to be the master, and turn the potentiometer of the other, "slave" power supplies, clockwise to the end. Then use the potentiometer of the master to adjust output voltage.
- When remote sensing is used in parallel operation, the sensing wire must be connected ONLY to the master.
- In parallel operation, output voltage increases like stairs due to a delay of the rise time of output voltage at turn on.

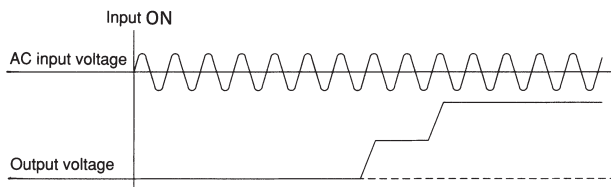

- In parallel operation, please connect diode to the +side of the output circuit. If diode is connected to the -side, it will damage the unit or/and the balancing function will not work.

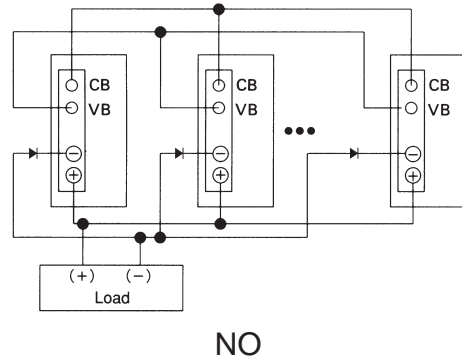
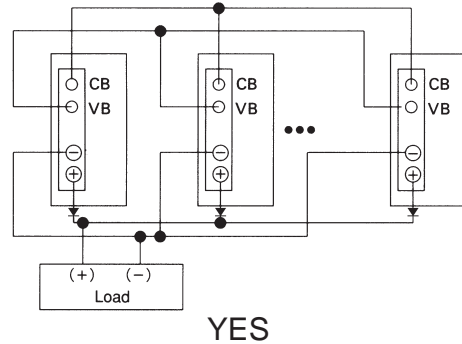

4 Assembling and Installation Method

4.1 Installation method

- When two or more power supplies are used side by side, position them with proper intervals to allow enough air ventilation. Ambient temperature around each power supply should not exceed the temperature range shown in derating curve.

4.2 Derating

- The operative ambient temperature is different by with/without case cover or mounting position. Please refer drawings as below.
- When unit mounted except below drawings, it is required to consider ventilated environment by forced air cooling or temperature/load derating. For details, please consult our sales or engineering departments.

●AD240

(1)Installation method

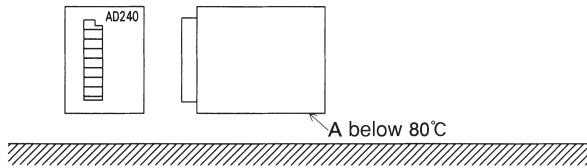

①A part should be kept below 80°C.

(When operating ambient temperature is at 45°C)

②Do not block the ventilation hole.

(2)Derating curve

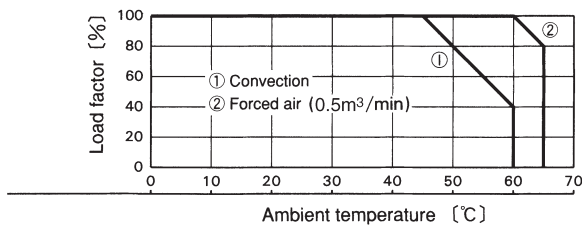

* 100% load factor means 240W of output power.

●AD480

(1)Installation method

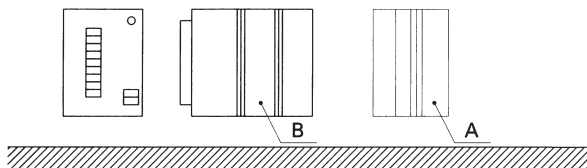

①Keep the temperature of part A and B as below chart.

●AD480-24

Operating condition	A part	B part
Forced air	Below 65	Below 61
Convection	Below 73	Below 72

(When operating ambient temperature is at 45°C)

②Do not block the ventilation hole.

(2)Derating curve

●AD480-24

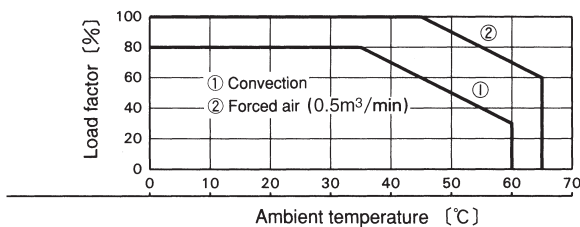

* 100% load factor means 480W of output power.

●AD960

(1)Installation method

■Cooling by Forced air

①Ventilate to get temperature as per drawing (Operating ambient temperature is at 45°C).

②Do not block the ventilation hole so that the air ventilates equally.

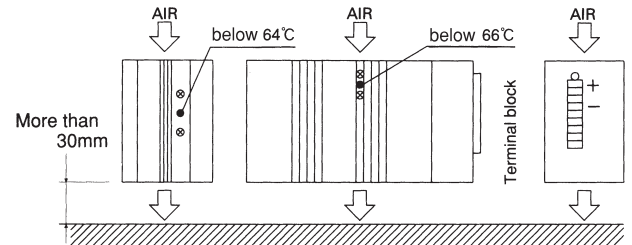

■Cooling by convection

①Install the unit as per drawing so that enough convection is applied.

②Do not block the ventilation hole.

* Consult factory if the unit needs to be mounted in a non-listed position.

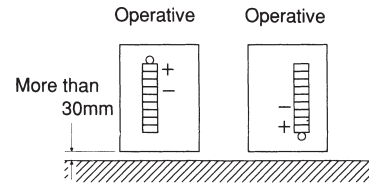

(2)Derating curve

■Operative ambient temperature varies depending on the cooling method. Please refer to the following derating curve.

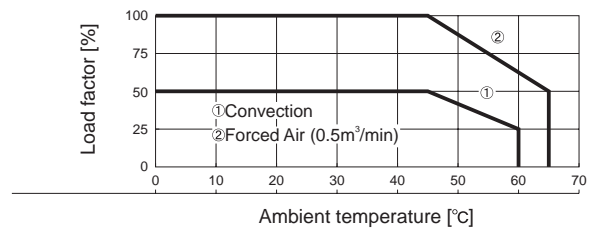

* 100% load factor means 960W of output power.

4.3 Mounting screw

■Keep isolation distance between screw and internal components, as below chart.

■Do not mount the unit only on the front side (terminal side) or the reverse side.

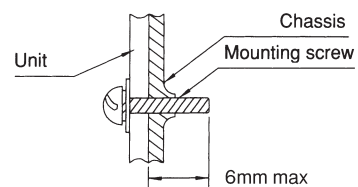

5 Peak Loading

AD

- When unit operates by pulse load, attach the external capacitor at output line which corresponds to peak value of pulse current (If the pulse current is drawn directly, it will shorten the life time of capacitor installed in the power supply).
- Due to the nature of a pulse load, a power supply may make a sound (noise). If the unit is used in a quiet place, consult factory for the load condition in advance.

● AD240

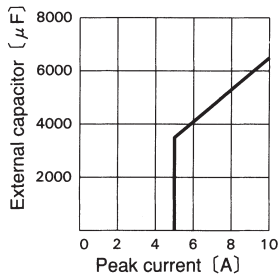

● AD480

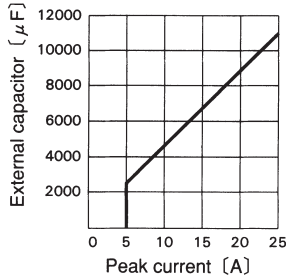

● AD960

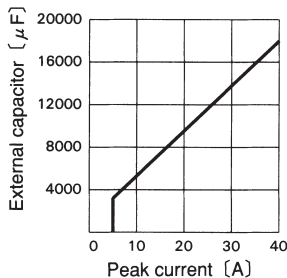

Note 1. Select an external capacitor with capacity above the line in the graph.

Note 2. Make sure ripple current of an external capacitor is allowable.

Note 3. Select the electrolytic capacitor with a capacity over 35V of its rated voltage.

Note 4. When the load current draws continuously, external capacitor is not necessary.