

External view

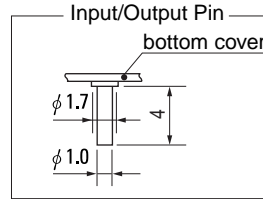
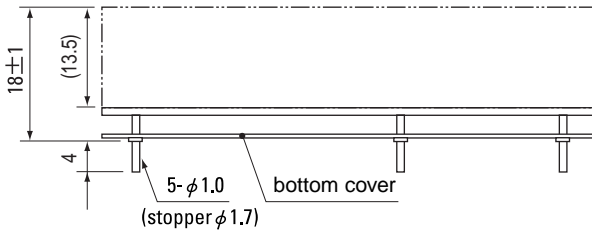
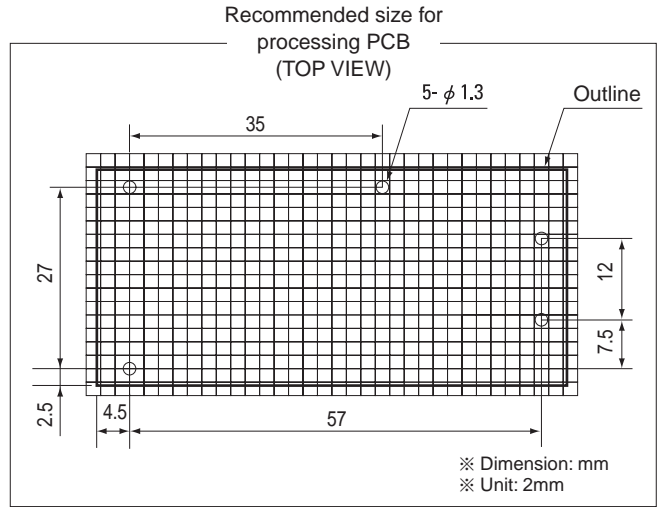
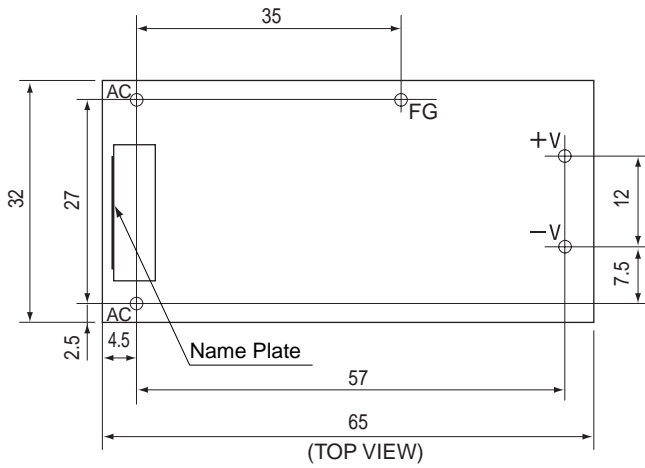

- ※ Weight: 30g or Less
- ※ Tolerance: ±0.5
- ※ PCB material: CEM-3
- ※ PCB thickness: t=1.0
- ※ Pin material: CPW with solder plated
- ※ Bottom cover material: Bake PL 1256 (Black)
- ※ Recommended hole dia. to PCB: φ1.3

Performance data

STATIC CHARACTERISTICS (VAA512)

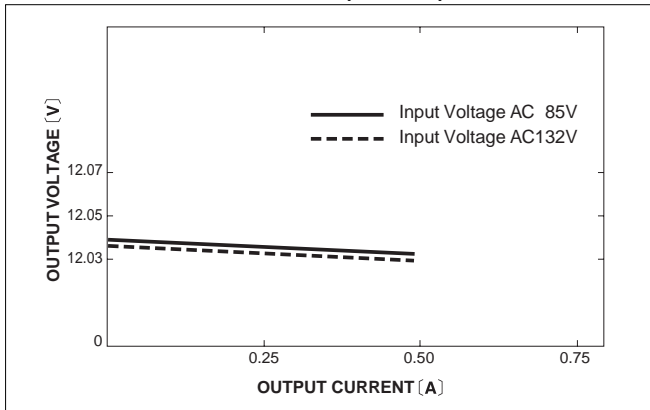

RISE TIME & FALL TIME (VAA512)

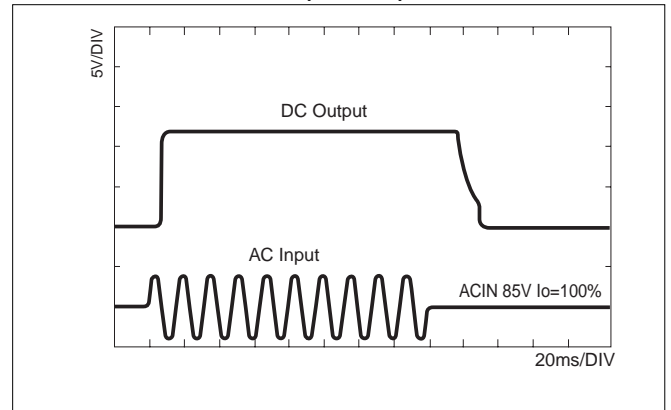

OVERCURRENT CHARACTERISTICS (VAA512)

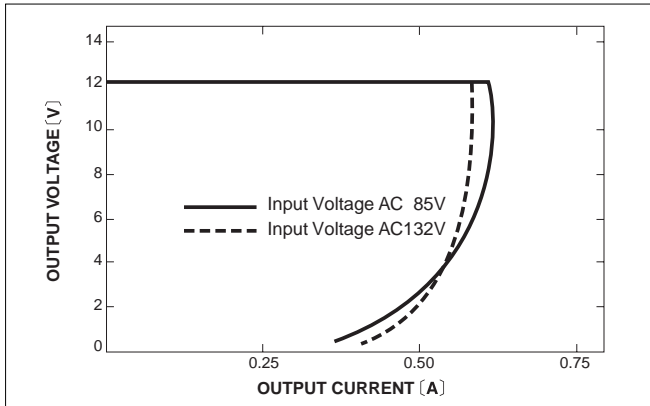

DERATING CURVE

