

External view

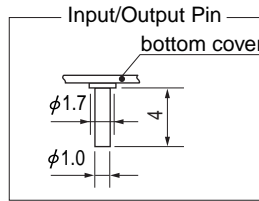
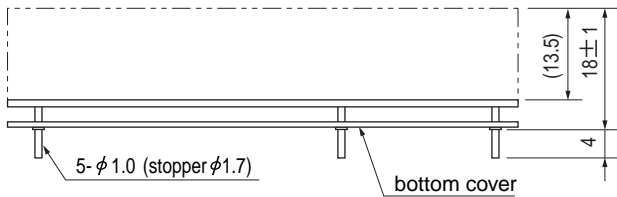
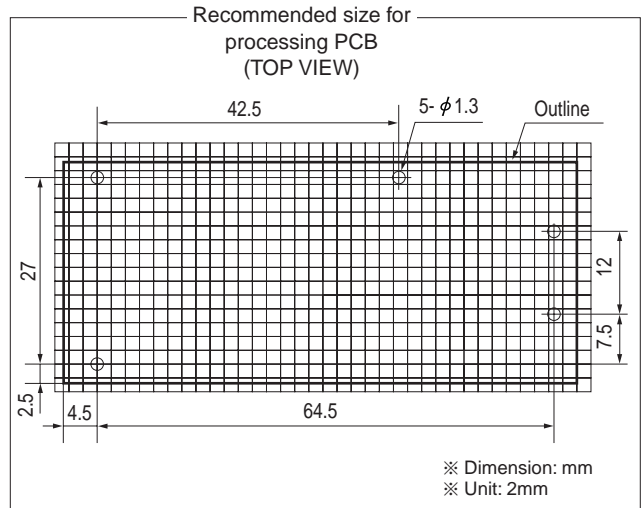
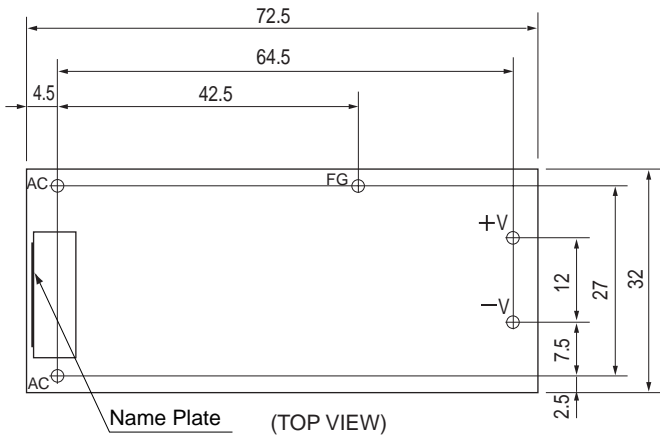

- ※ Weight: 35g or Less
- ※ Tolerance: ± 0.5
- ※ PCB material: CEM-3
- ※ PCB thickness: $t=1.0$
- ※ Pin material: CPW with solder plated
- ※ Bottom cover material: Bake PL 1256 (Black)
- ※ Recommended hole dia. to PCB: $\phi 1.3$

Performance data

■ STATIC CHARACTERISTICS (VAA1012)

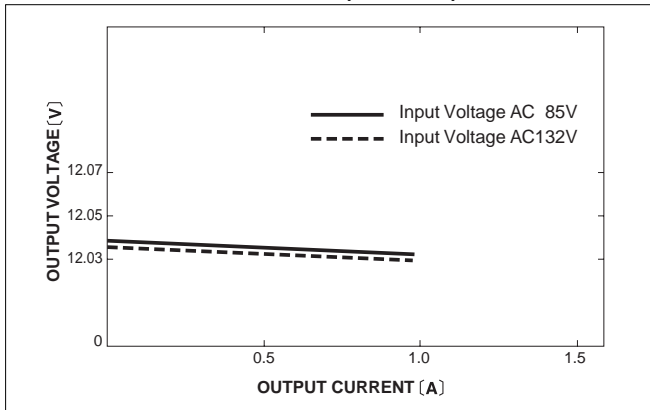

■ RISE TIME & FALL TIME (VAA1012)

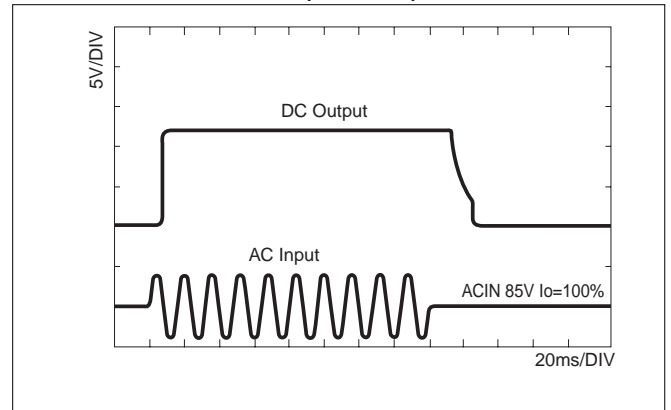

■ OVERCURRENT CHARACTERISTICS (VAA1012)

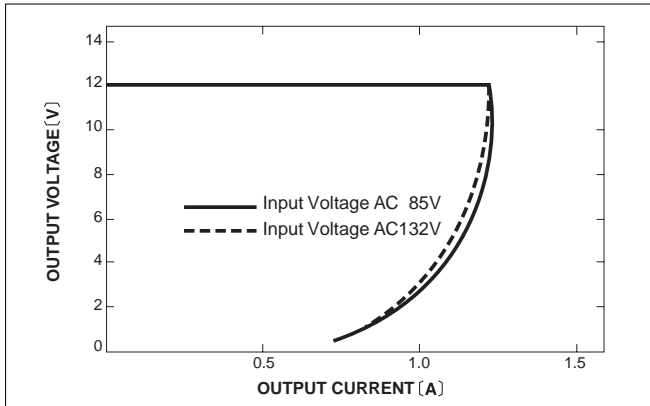

■ DERATING CURVE

