

External view

1.SMD(Type:A,B)

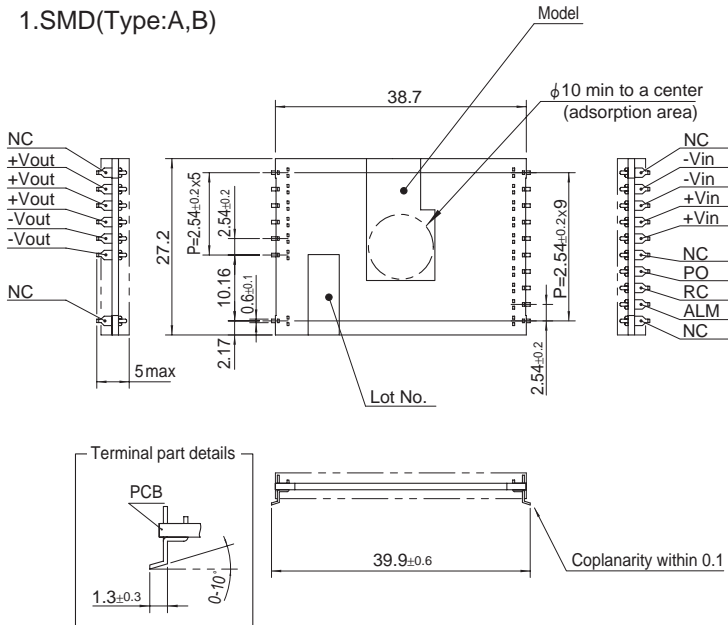

Recommended size for processing PCB (TOP VIEW)

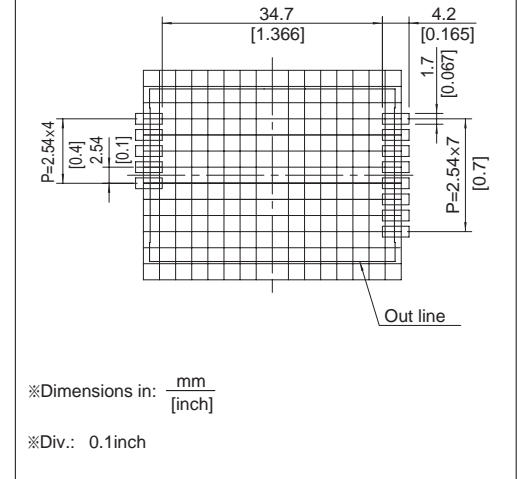

2.DIP(Type:C)

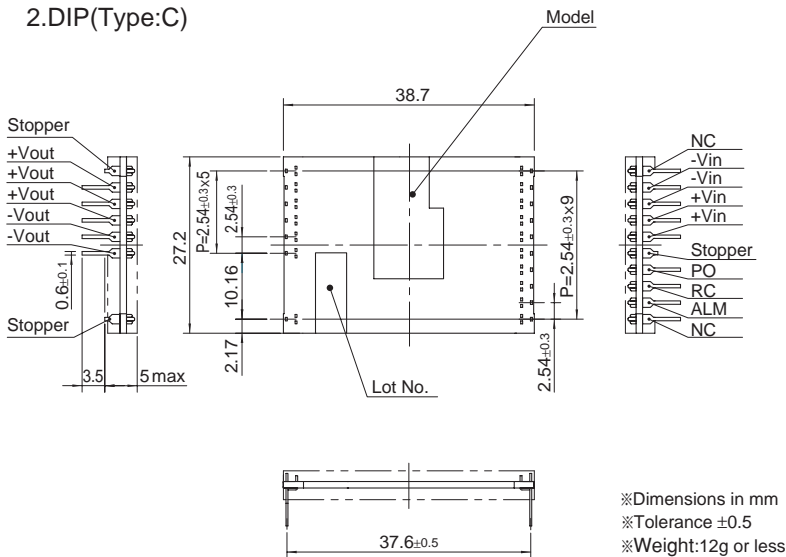

Recommended size for processing PCB (TOP VIEW)

