

Block diagram

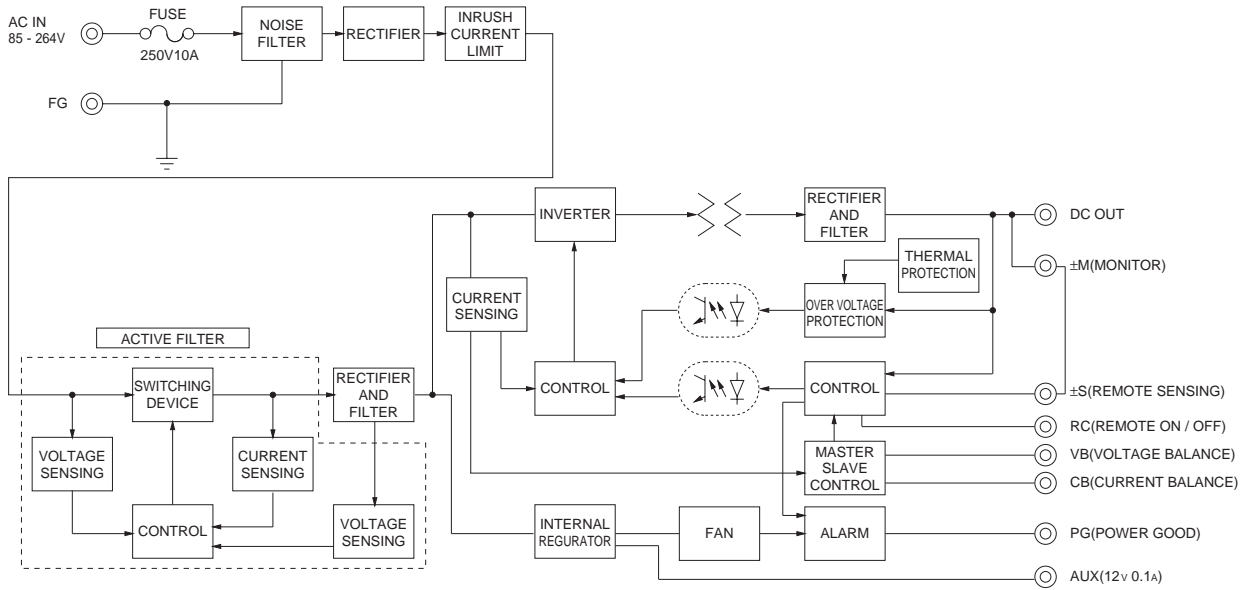

External view

