

External view

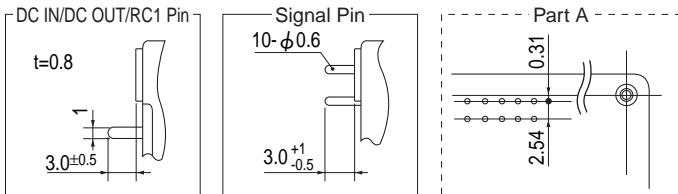
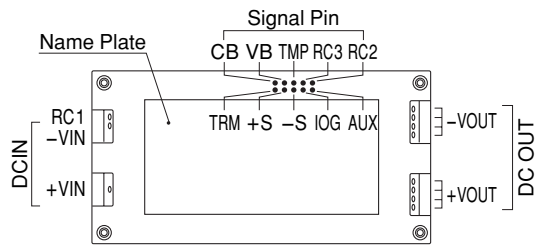
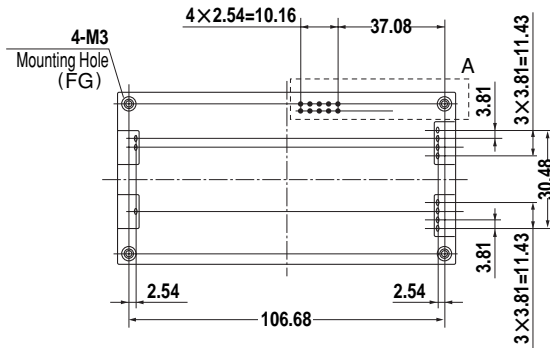
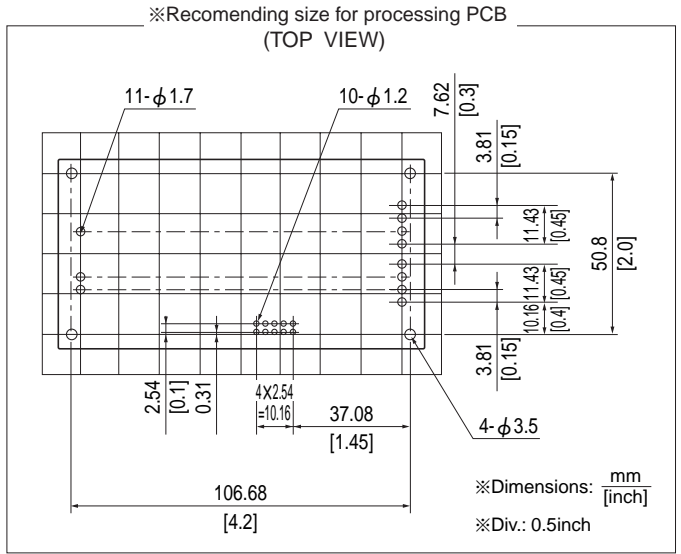
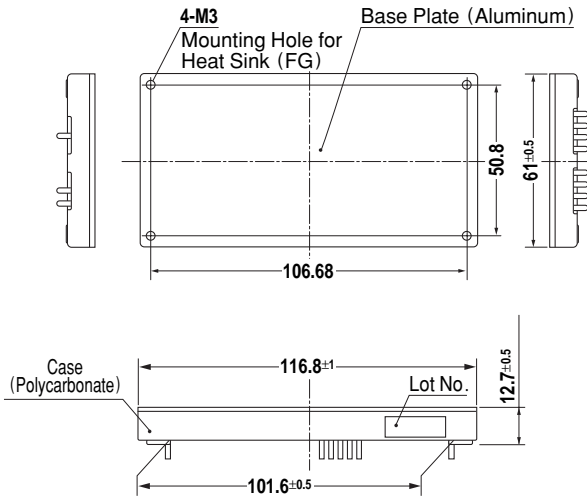

- ※Weight: 180g or less
- ※Tolerance: ±0.3
- ※Base Plate: Aluminum
- ※Dimensions in mm.
- ※Mounting hole screwing torque: 0.4N · m(5.0kgf · cm)

Performance data

INPUT CURRENT CHARACTERISTICS (DBS400B12)

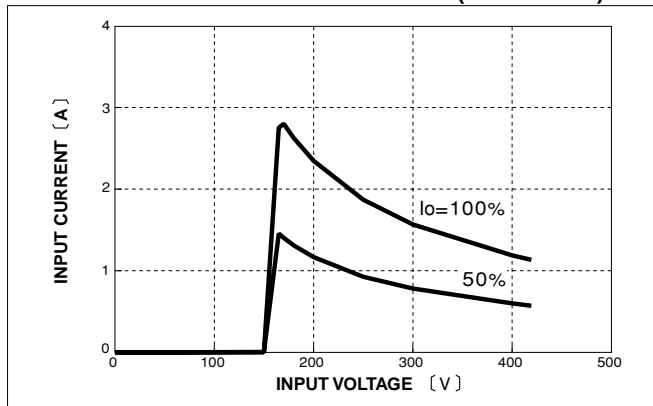

EFFICIENCY CHARACTERISTICS

