

External view

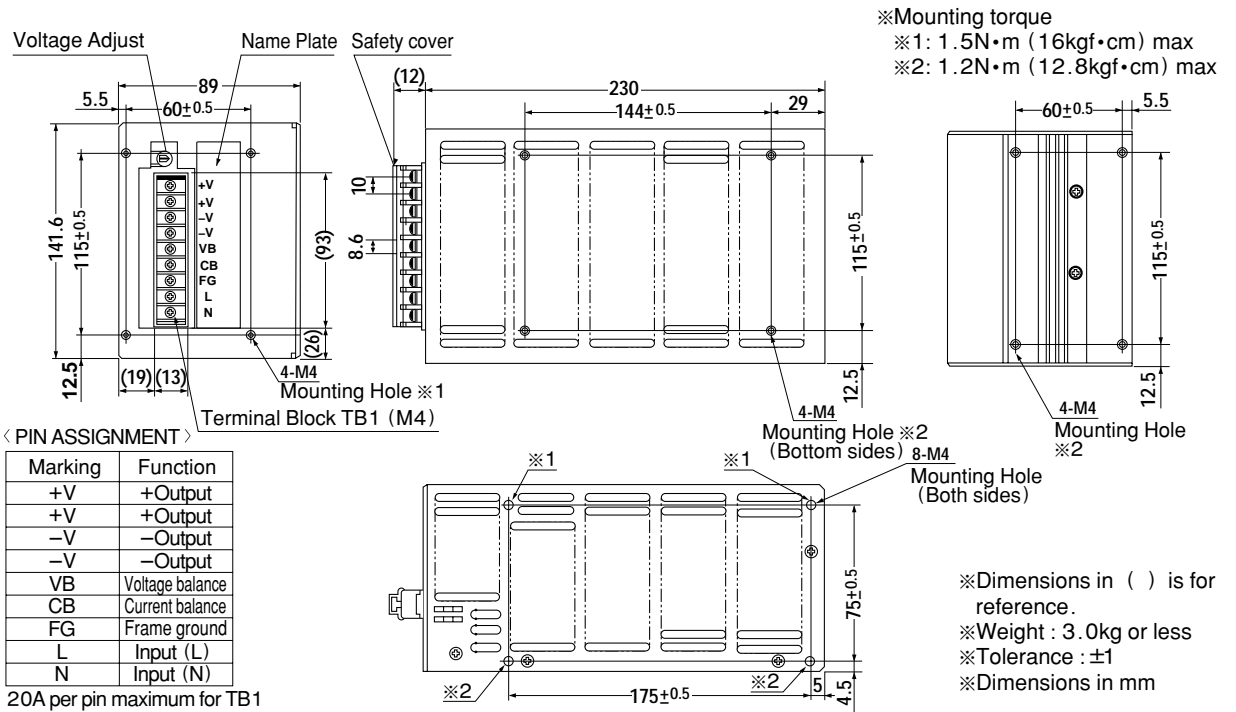

AD

Performance data

■ STATIC CHARACTERISTICS

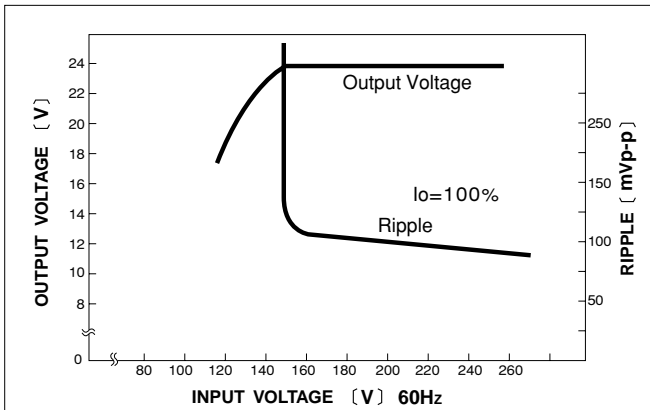

■ RISE TIME & FALL TIME

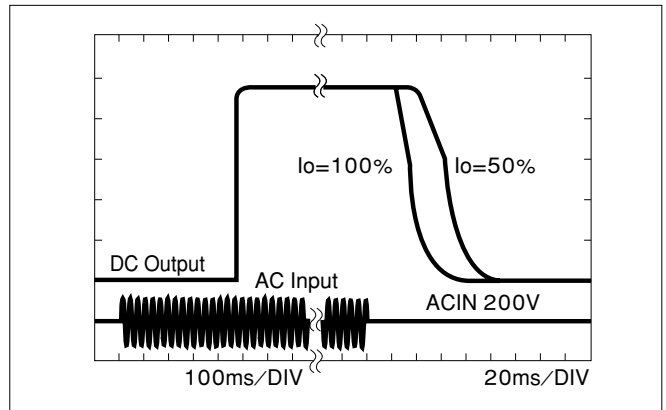

■ OVERCURRENT CHARACTERISTICS

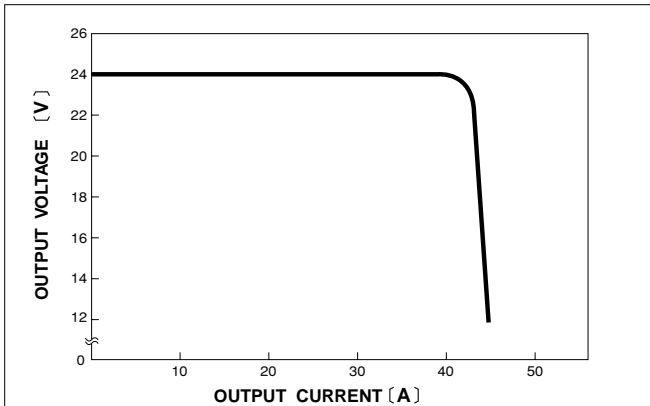

■ DERATING CURVE

