

External view

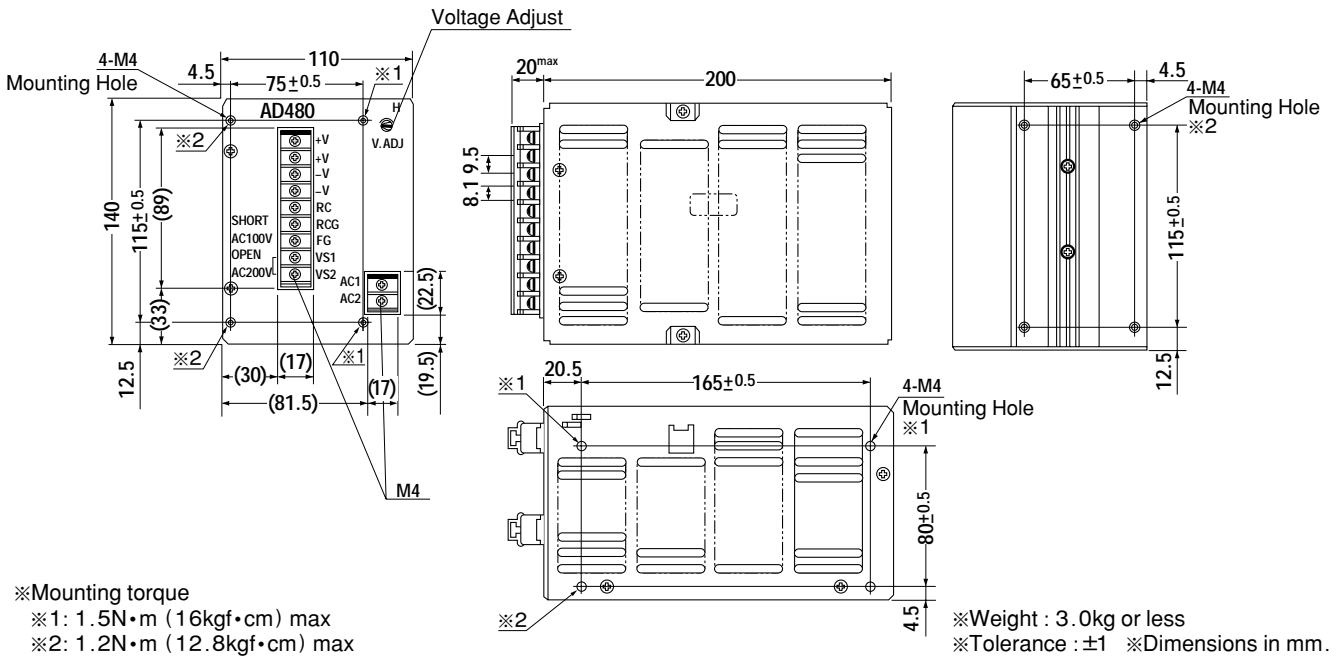

AD

Performance data

■STATIC CHARACTERISTICS

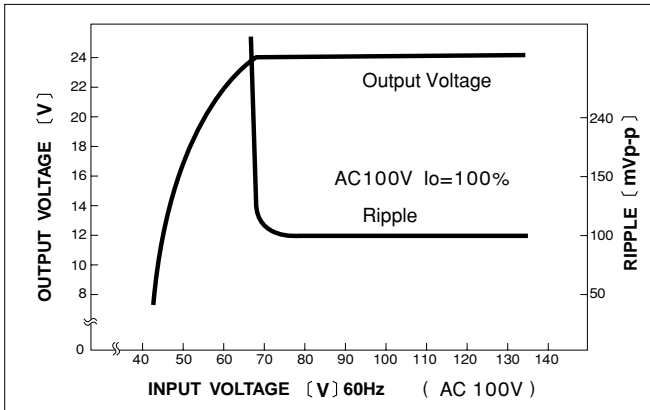

■RISE TIME & FALL TIME

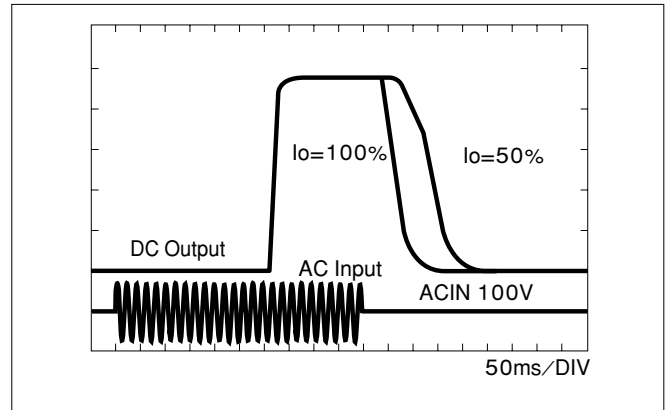

■OVERCURRENT CHARACTERISTICS

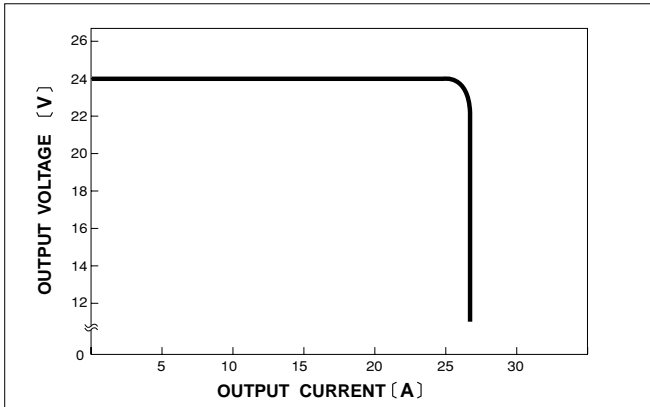

■DERATING CURVE

