

2004.12.06 Preliminary

DESCRIPTION

The AP1098 is a linear, low current power amplifier in ISM band utilizing InGaP /GaAs HBT process. It features a LOW current of **85mA**, small signal gain of 25 dB, linear power of **19dBm** and PAE of **28%** for 802.11g under 3.3V. It can also be adjusted to smaller current (~60mA) with lower linear power (~16dBm). The AP1098 is housed in a 3 x 3 (mm), 16-pin, and QFN leadless package. The AP1098 is suitable to be used in portable, low current 802.11b and 802.11g WLAN applications. AP1098 is also suitable for Bluetooth™ Class1 Application, please refer to appendix 1 for detailed info.

Major Applications

- IEEE 802.11b/g WLAN system
- WLAN Portable Devices
- WLAN USB Devices
- Bluetooth and other 2.4 GHz ISM Band Application

Functional Block Diagram

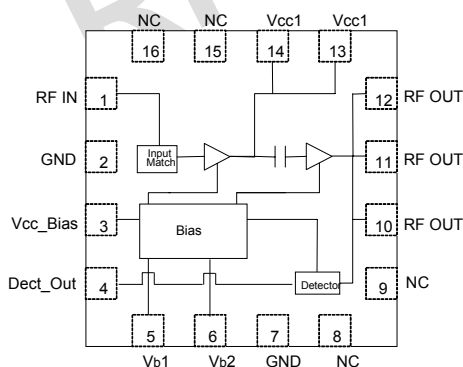

QFN- 16 pin, 3 x 3 (mm)

☺ Vb2 can be connected with Vb1 pin into a single Vref through external resistor. (Please refer to the AP1098 Application note)

For more information, please contact us at:

Sales Dept.

Tel: +886-2-2698-1022

e-mail: sales@rfintc.com

RF integrated Corp. reserves the right to make any changes to the specifications without notice.

KEY FEATURES

- Ultra LOW Current (see below specs)
 - Ultra High Efficiency:
 - PAE>28% @802.11g linear power
 - Gain: 25 dB
- Under Vc=3.3V, Vref=3V
- * 11g
 - linear power: 19dBm
 - current: 85mA
 - * 11b
 - linear power: 23dBm
 - current: 165mA
 - Low Idle Current: 25mA

Pin Details

Pin Number	Name	Description
1	RF_IN	RF input.
2	GND	DC and RF ground.
3	Vcc_Bias	Supply voltage for bias circuit.
4	Dect_Out	Power detector output.
5	Vb1	1 st -stage control voltage
6	Vb2	2 nd -stage control voltage
7	GND	DC and RF ground.
8	NC	No contact (Connect to ground for better thermal dissipation.)
9	NC	No contact (Connect to ground for better thermal dissipation.)
10	RF_OUT	RF output. Require external matching.
11	RF_OUT	The detail configuration can be found in Application Notes
12	RF_OUT	The detail configuration can be found in Application Notes
13	VCC1	Supply voltage for first stage. Some bypass capacitors are needed for system application. The detail configuration can be found in Application Notes.
14	VCC1	Supply voltage for first stage. Some bypass capacitors are needed for system application. The detail configuration can be found in Application Notes.
15	NC	No contact (Connect to ground for better thermal dissipation.)
16	NC	No contact (Connect to ground for better thermal dissipation.)
Package Base	Center Metal	The package ground provides circuit ground as well as heat dissipation path for the power amplifier.

2004.12.06 Preliminary

Electrical Characteristics

Under $V_c=3.3V$, $V_{ref}=3V$, $T_a=25^\circ C$

Parameter	Symbol	Test conditions	Min.	Typ.	Max.	Unit
Freq.	f		2.4		2.5	GHz
Total current	I _{cc}	@ P _{out} =19dBm, 64QAM/54Mbps @ P _{out} =23dBm, CCK/11Mbps		85 165		mA
Bias control reference current	I _{ref}	@ I _{cq} =25mA		0.7		mA
Power Gain	G _p	@ P _{out} =19dBm, 64QAM/54Mbps		25		dB
Quiescent current	I _{cq}			25		mA
EVM at Output power 19dBm	EVM	@ P _{out} =19dBm, 64QAM/54Mbps		3		%
802.11b ACP-1 st Side Lobe		@ P _{out} =23dBm, CCK/11Mbps		-36		dBc
802.11b ACP-2 nd Side Lobe		@ P _{out} =23dBm, CCK/11Mbps		-56		dBc
Input VSWR				2		
Output VSWR				2.5		
PAE @ linear power	PAE	@ P _{out} =19dBm, 64QAM/54Mbps @ P _{out} =23dBm, CCK/11Mbps		28 37		%

Absolute Maximum Ratings

Parameter	Rating	Unit
DC Power Supply For Collector	+5	V
DC Supply Current For Collector	280	mA
RF Input Power	+5	dBm
Operating Ambient Temperature	-40 to +85	°C
Storage Temperature	-40 to +125	°C

Important Note:

The information provided in this datasheet is deemed to be accurate and reliable only at present time. RF Integrated Corp. reserves the right to make any changes to the specifications in this datasheet without prior notice.

For more information, please contact us at:

Sales Dept.

Tel: +886-2-2698-1022

e-mail: sales@rfintc.com

© 2003 RF Integrated Corporation. All rights reserved.

RF integrated Corp. reserves the right to make any changes to the specifications without notice.

2004.12.06 Preliminary

Data Charts

Fig. 1

EVM & Icc vs. Pout (dBm)@3.3V

(Vc1=Vc2=Vcc_bias=3.3V, Vref=3V, f=2.447GHz, 54Mbps OFDM Signal)

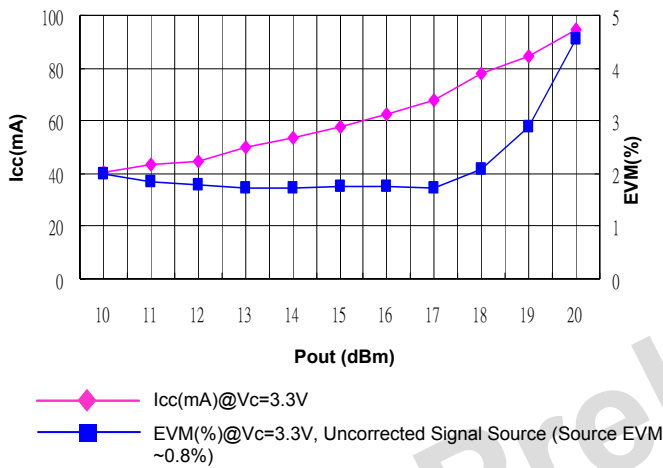

Fig. 2

Gain, EVM, PAE vs Pout

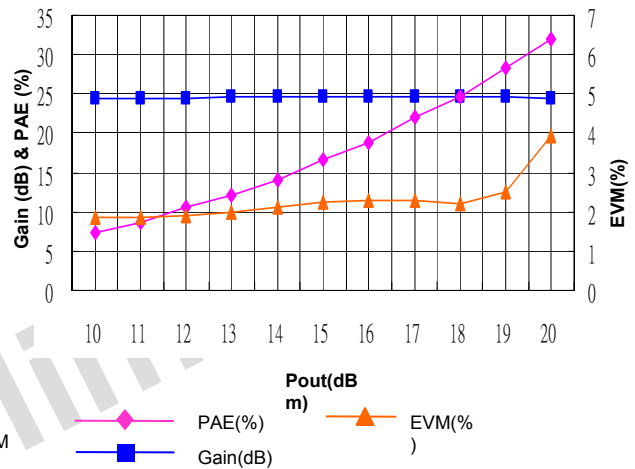

Fig. 3

Detector Output vs. Output Power

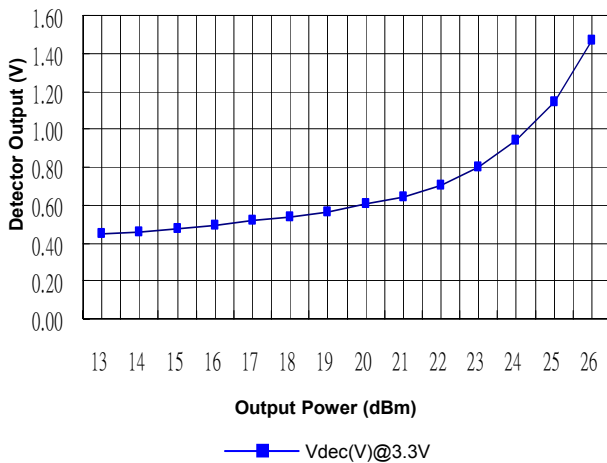
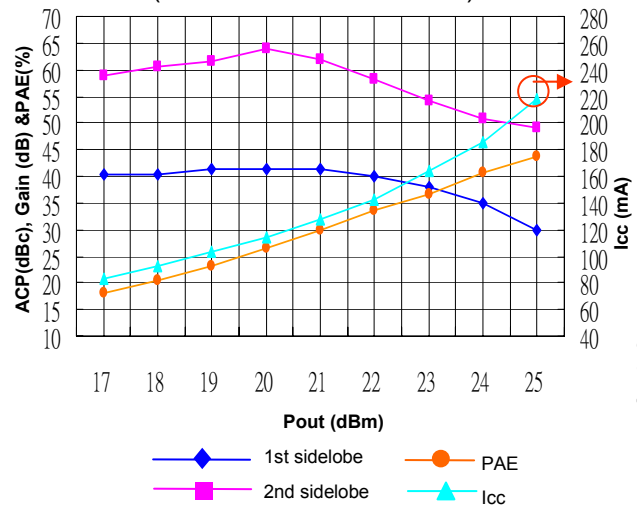

Fig. 4

Gain, ACP, PAE, Icc vs Pout_3.3V (With 11b CCK Modulation)



AP1098

For more information, please contact us at:

Sales Dept.

Tel: +886-2-2698-1022

e-mail: sales@rfintc.com

© 2003 RF Integrated Corporation. All rights reserved.

RF integrated Corp. reserves the right to make any changes to the specifications without notice.

2004.12.06 Preliminary

Data Charts

Fig.5

Power Gain vs. Frequency

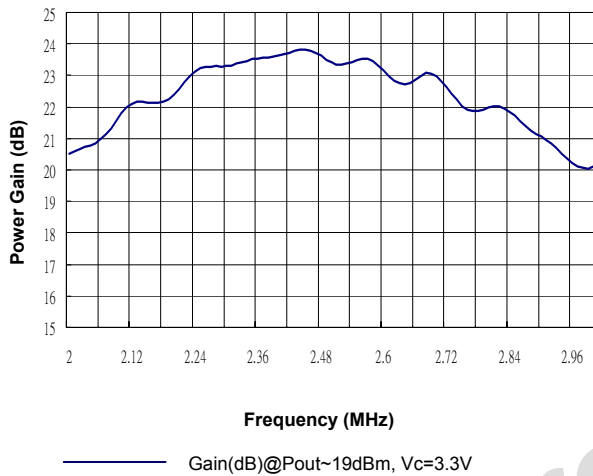

Fig. 6

Input Return Loss vs. Frequency

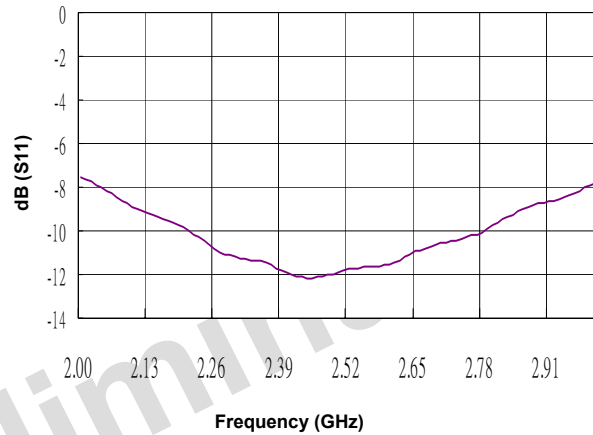

Fig. 7

Output Return Loss vs. Frequency

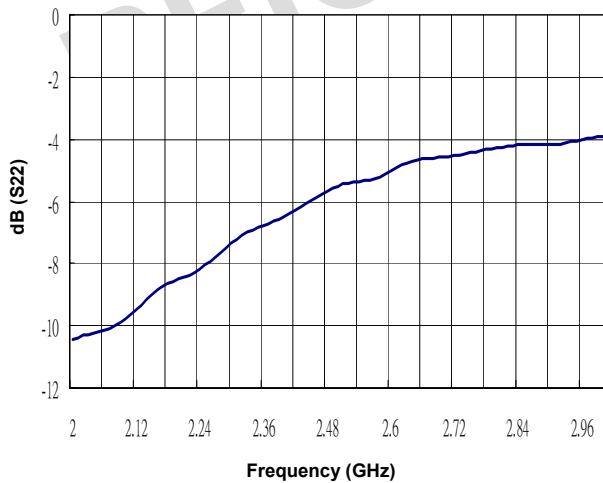
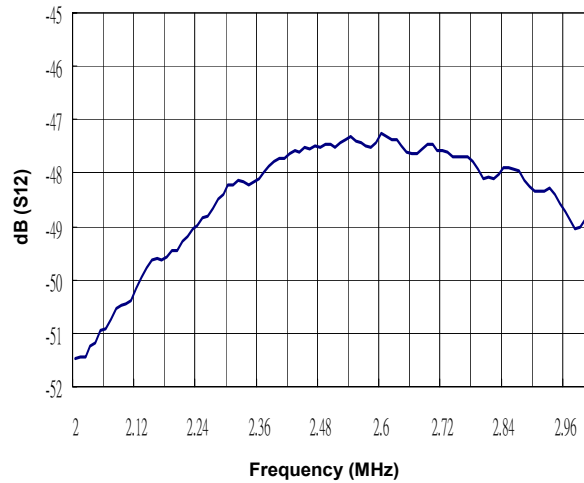

Fig. 8

Reverse Isolation vs. Frequency



For more information, please contact us at:

Sales Dept.

Tel: +886-2-2698-1022

e-mail: sales@rfintc.com

© 2003 RF Integrated Corporation. All rights reserved.

RF integrated Corp. reserves the right to make any changes to the specifications without notice.

2004.12.06 Preliminary

Package Outline

Top View

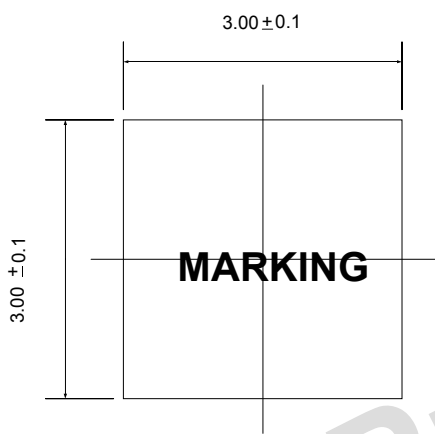

Bottom View

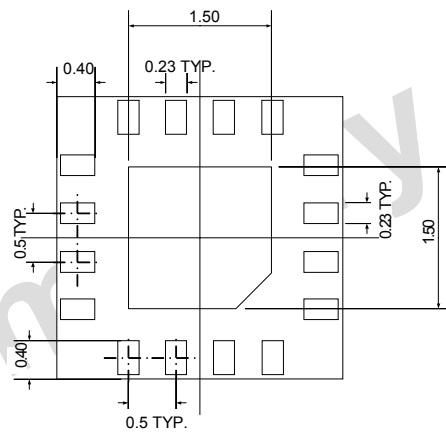

Unit: mm

Side View

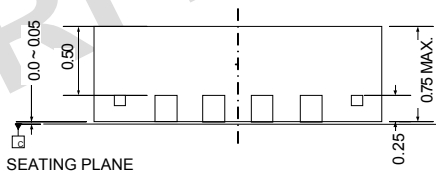

Note :

1. Dimension and tolerance conform to ASME Y14.5M-1994.
2. Refer to JEDEC STD. MO-220 WEED-2 ISSUE B

© For more detailed information, please refer to AP1098 Application Note.

For more information, please contact us at:

Sales Dept.

Tel: +886-2-2698-1022

e-mail: sales@rfintc.com

© 2003 RF Integrated Corporation. All rights reserved.

RF integrated Corp. reserves the right to make any changes to the specifications without notice.

2004.12.06 Preliminary

Appendix 1: Bluetooth Class1 Application

DESCRIPTION

The AP1098 is a linear, low current power amplifier in ISM band utilizing InGaP /GaAs HBT process. It features a LOW current of **85mA**, small signal gain of 24dB, typical power of **20dBm** and for Bluetooth Class 1 under 3.3V. The AP1098 is housed in a 3 x 3 (mm), 16-pin, and QFN leadless package.

KEY FEATURES

- **LOW Current** (see below specs)

- **Gain: 24 dB**

Under Vc=3.3V, Vref=2.85V

typical power: 20dBm

current: 85mA

Electrical Characteristic		Under Vc=3.3V, Vref=2.85V				
Parameter	Symbol	Teat conditions	Min.	Typ.	Max.	Unit
Freq.	f		2.4		2.5	GHz
Total current	Icc	Pout=22dBm	105	110	120	mA
Basic control reference current	Iref	Icq=18mA		0.5		mA
Power Gain	Gp	Pout=20dBm	23	24	25	dB
Quiescent current	Icq			20		mA
Input VSWR				2		
Output VSWR				2.5		
PAE	PAE			41		%

2004.12.06 Preliminary

**Appendix 1: Bluetooth Class1
Data Charts**

Fig.1

Pout & PAE vs. Pin

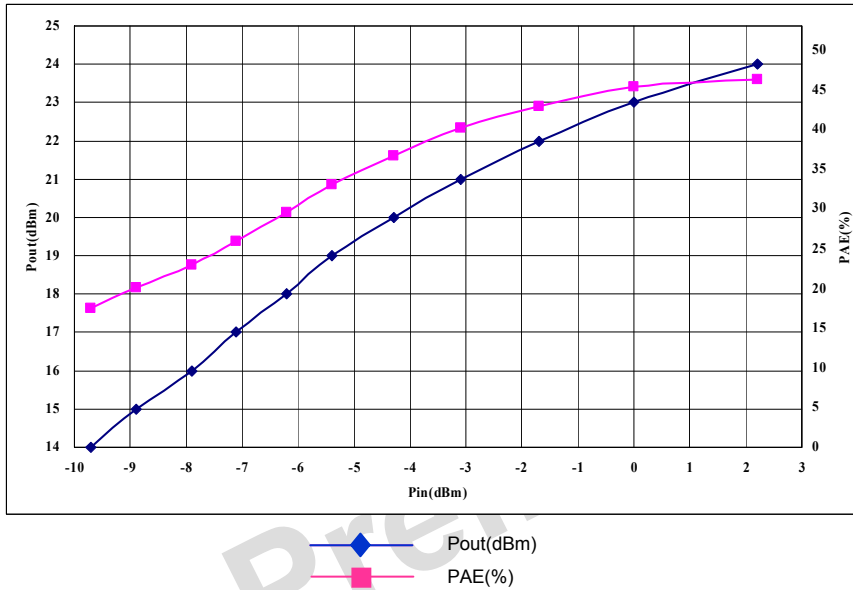
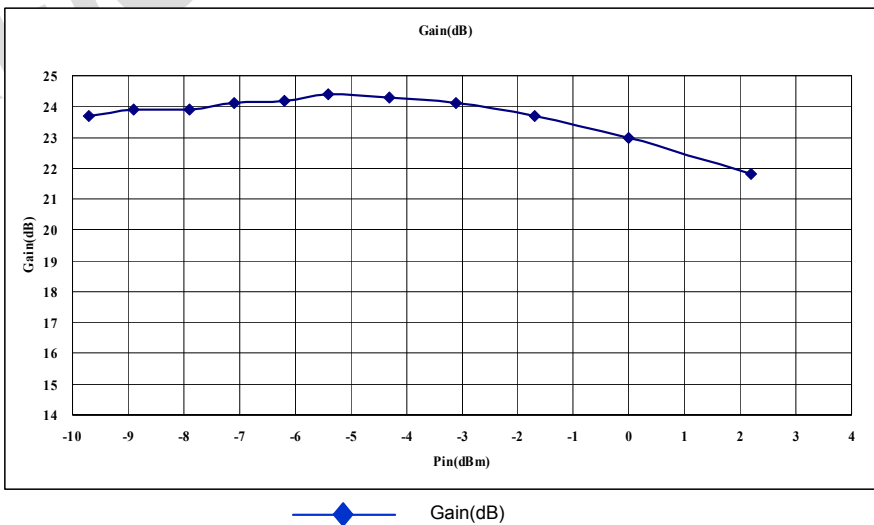

Fig.2

Power Gain vs. Pin



AP1098

For more information, please contact us at:
Sales Dept.
Tel: +886-2-2698-1022
e-mail: sales@rfintc.com

© 2003 RF Integrated Corporation. All rights reserved.

RF integrated Corp. reserves the right to make any changes to the specifications without notice.

2004.12.06 Preliminary

Appendix 1: Bluetooth Class1 EVB Circuit Diagram

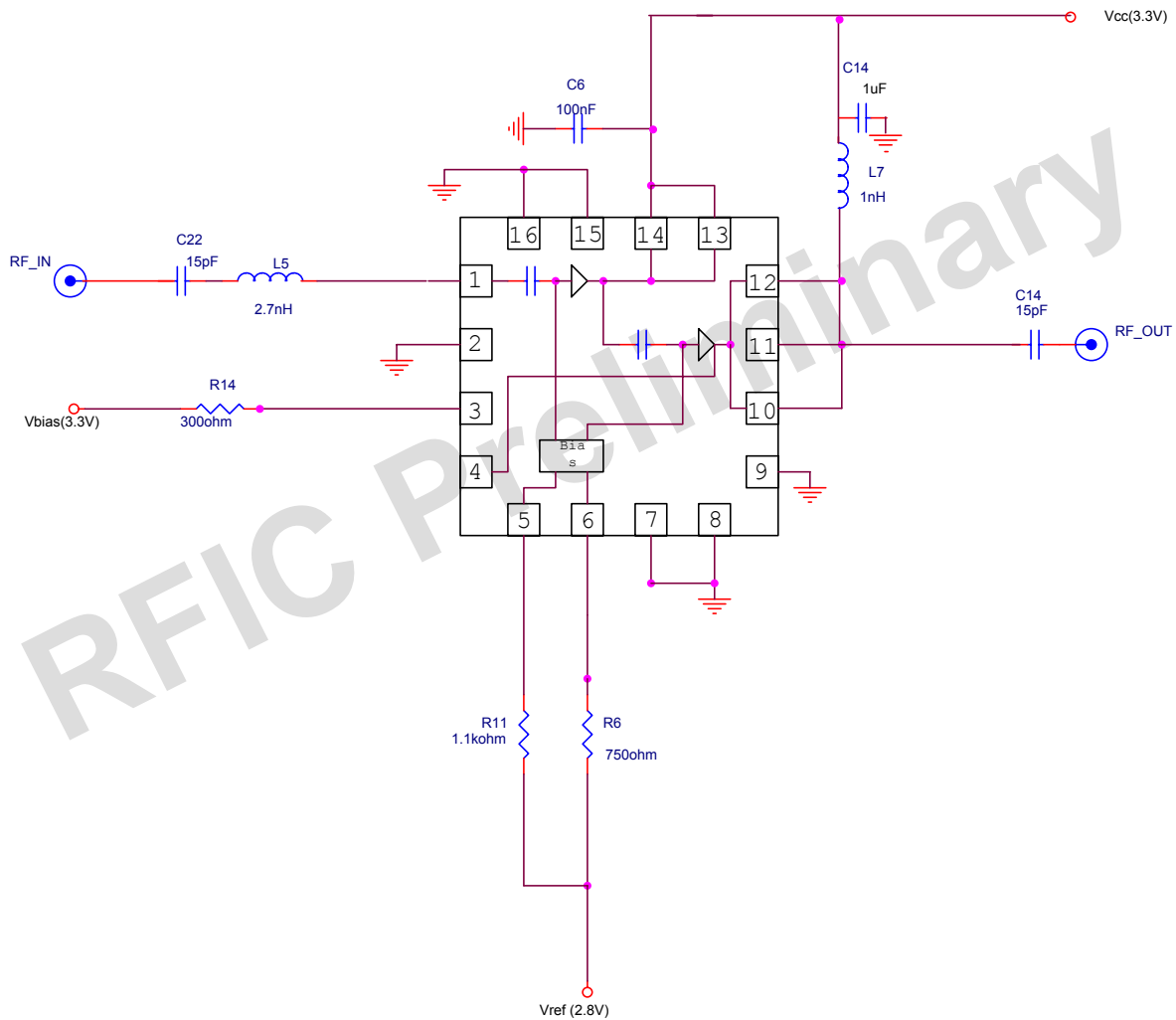

AP1098

For more information, please contact us at:

Sales Dept.

Tel: +886-2-2698-1022

e-mail: sales@rfintc.com

© 2003 RF Integrated Corporation. All rights reserved.

RF integrated Corp. reserves the right to make any changes to the specifications without notice.